

## Monitoring and Analysis Plan for Aegis AGEN-75 CHP System at the Trump Towers City Center

This document describes the measurements, sensors, and data logging equipment proposed to quantify the performance of the Aegis AGEN-75 based CHP system installed at the Trump Tower City Center in White Plains, NY. The CHP system consists of two Aegis AGEN-75 75-kW engine generator systems that produce electricity and hot water for domestic hot water and space heating.

Figure 1 displays one of two of the engine generator units (typical of both units). The units are located on the 35<sup>th</sup> floor mechanical room, along with the associated pumps and heat exchangers. The dry-cooler dump radiators are located on the roof outside the mechanical room. Also located in the mechanical room are storage style natural gas water heaters, and the space heating hot water boiler.



Figure 1. Aegis Energy Services AGEN-75 Engine Generator (1 of 2 typ)



Figure 2. CHP Skid Heat Recovery Piping, Circulation Pumps, and HX

**Description of Monitored Data Points**

Table 1 lists the monitored points required to characterize the performance of the CHP system. Each point is accompanied by the respective sensor and engineering unit measured.

**Table 1. Data Point List**

No	Data Point	Description	Sensors	Units	Notes
1	WG1	Engine generator #1 energy	Veris H8053-400	kWh	No meter supplied by applicant - CDH Energy will supply power meter 0.1 kWh/pulse
2	WG2	Engine generator #2 energy	Veris H8053-400	kWh	No meter supplied by applicant - CDH Energy will supply power meter 0.1 kWh/pulse
3	WPAR	Parasitic energy (pumps, dump radiator fans)	Wattnode WNB-3Y-208-P	kWh	No meter supplied by applicant - CDH Energy will supply power meter 1.25 Wh/pulse, 50-AMP CTs
4	TLS	Heat recovery loop supply temperature	Type II 10k Ohm Thermistor	deg F	CDH Energy to supply strap-on style sensor
5	TLR1	Heat recovery loop return temperature after load HXs	Type II 10k Ohm Thermistor	deg F	CDH Energy to supply strap-on style sensor
6	TLR2	Heat recovery loop return temperature after dump radiator	Type II 10k Ohm Thermistor	deg F	CDH Energy to supply strap-on style sensor
7	FL	Heat recovery loop flow	ISTEC 1820 flow meter	gallons	Applicant supplied meter, 10 gallon/pulse
8	FG	Natural gas	Con Ed Billing Meter (monthly reads)	CCF	No access to natural gas meter is available, revenue meter is located in basement meter room with no connecting conduit. Con-Ed monthly billing data used to for natural gas consumption.

Figure 3 displays a schematic of the location of monitored data points.

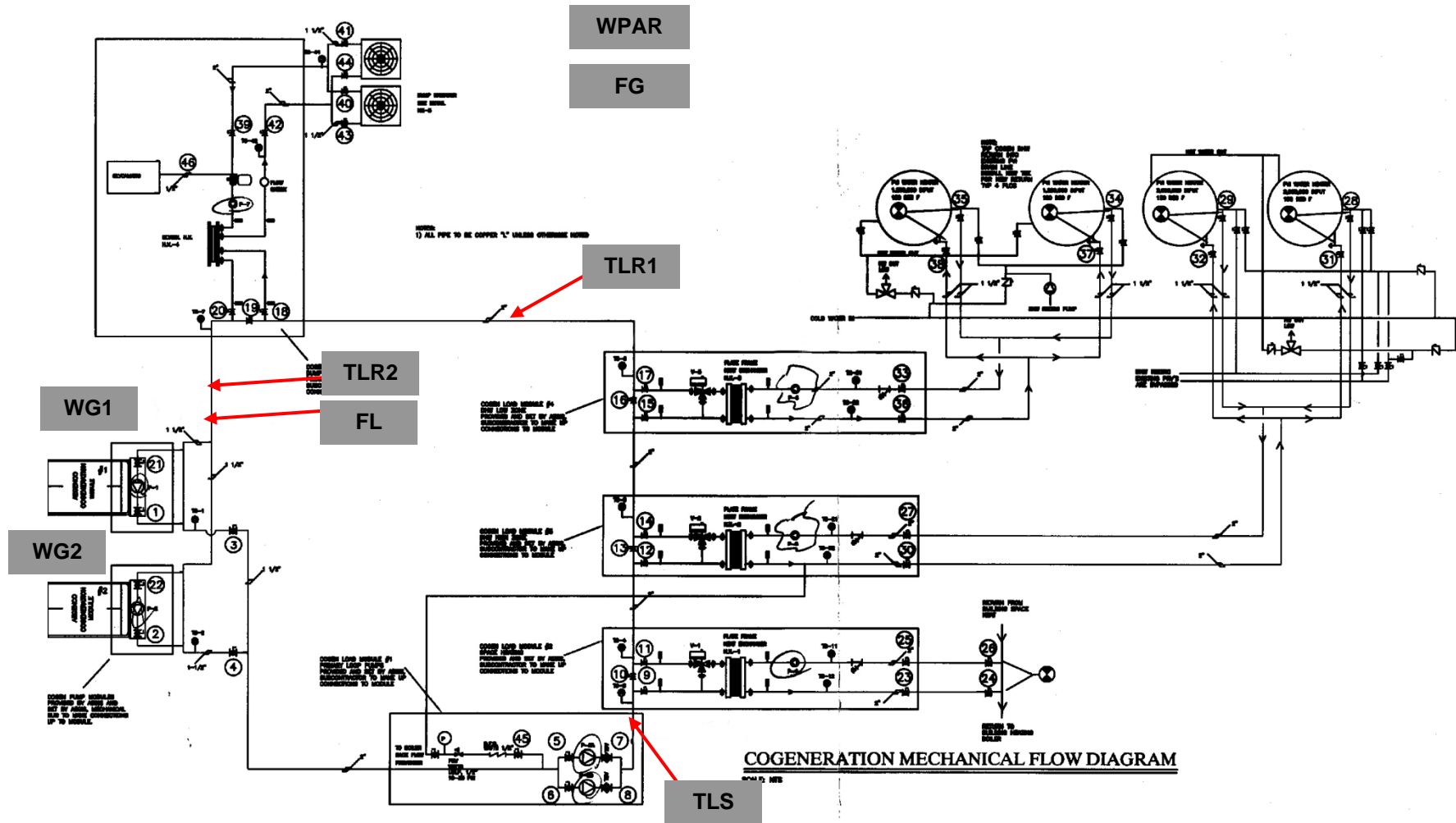

Figure 3. Location of Monitored Points on System Schematic Drawing

### **Power Meters (WG1, WG2, WPAR)**

No applicant supplied power meters are available at the site, for either the CHP generators or parasitic power loads. CDH Energy will lease power meters to the project for \$500 each for the duration of performance monitoring.

One power meter per engine will be located in the disconnects for the engine generator (Figure 4), or in the engine control section themselves (depending on space available for the meters).



**Figure 4. Engine Generator Disconnection Location of Power Transducer (1 of 2 typ)**

Parasitic power loads are mostly contained in a single contactor panel (CCP-1) (see Figure 5), containing Cogen Loop Pumps (P-1 & P-2), Primary Loop Pump (P-3a & P-3b), Building Heating Loop Pump (P-4), and Dump Radiator Loop Pump (P-7), and Dump Radiator Dry-Coolers 1 & 2 (see Figure 6 and Figure 7).

The parasitic load panel transducer was also not supplied by the applicant. CDH Energy will purchase a power transducer sized for this location (50 amps) and provide to the project at cost. The parasitic load power transducer will be installed inside panel CCP-1, in the open section at the lower right side of the panel (Figure 5).





**Figure 5. Parasitic Load Panel CCP-1**



*Primary Loop Pumps P-3a, P-3b*



*Building Heating Loop Pump P-4 and HX*

**Figure 6. Parasitic Loads Fed From Panel CCP-1**



*Dump Radiator Loop Pump P-7 and HX*



*Dump Radiator Dry-Coolers*

**Figure 7. Parasitic Loads Fed From Panel CCP-1 (continued)**

The DHW circulating pumps (P-5 and P-6) are small constant duty pumps which are not controlled by the contactors in Panel CCP-1. Power for these pumps will be determined by a one-time power reading, and added to the measured system parasitic power.



*DHW Low Zone Pump (P-5) and HX*



*DHW High Zone Pump (P-6) and HX*

**Figure 8. Constant Operation Parasitic Loads Fed Not From Panel CCP-1**



**Temperature Sensors (TLS, TLR1, TLR2)**

Only two of the three sensor locations have applicant supplied wells. To keep temperature differences consistent, surface mount strap-on style sensors with thermal conductive grease will be used. The system piping is Type L copper that has sufficient conductivity to for a surface mount application. The piping will be thoroughly cleaned prior to securing the sensor to the piping with a ring clamp. Insulation will be replaced and taped over the sensor locations.



Figure 9. Location of Temperature Sensors on CHP Piping

**Heat Recovery Loop Flowmeter (FL)**

The heat recovery loop flowmeter is an existing sensors located on the cogen loop returning to the engines (downstream of the TLR2 sensor location). The meter was installed by the applicant for the purpose of NYSERDA performance monitoring, and will be utilized by the monitoring system.



**Figure 10. Heat Recovery Loop Flowmeter**

### **Natural Gas Flow (FG)**

The natural gas meter for the CHP system is located in the basement/parking garage level in a metering room more the 35 stories down from the penthouse mechanical room. There are no connecting conduits from the metering room to the penthouse mechanical room, and no local gas meter in the penthouse mechanical room. There exists no way to connect a gas meter to the data logging system.

Because of this gas metering situation, we are recommending that the CHP efficiency for this site be evaluated monthly, based on the utility natural gas billing data. The applicant/site will be required to submit utility data to CDH Energy on a frequent and reoccurring basis, no later than five days from receipt of the utility bill.

The monthly utility consumption will be turned into an average hourly consumption for inclusion into the NYSERDA integrated data system.





**Figure 11. Utility Gas Meter In Basement Metering Room**

**Data Logger Location and Communication**

The data logger will be installed by the existing internet router at the far left side of the CHP piping skid. Inside the Aegis communication panel is a 110 VAC outlet that will be utilized for datalogger power.



*Data Logger Location and Existing Router*



*Aegis Communication Panel with 110 VAC Outlet*

**Figure 12. Data Logger Location, Communication and Power**

### Data Analysis

The collected data will be used to determine the net power output of the system as well as the fuel conversion efficiency (FCE).

#### Peak Demand or Peak kW

The peak electric output or demand for each power reading will be taken as the average kW in a 1-minute interval, or

$$\text{kW} = \frac{\text{kWh}}{\Delta t} = \frac{\text{kWh per interval}}{1/60 \text{ h}}$$

#### Heat Recovery Rates

The heat recovery rates will be calculated based on the 1-minute data recorded by the data logger. The piping arrangement at this site requires for separate heat rates to be determined with four temperature sensors and two flow readings:

$$\text{Useful heat recovery (QHU)} = K \cdot \Sigma [\text{FL} \cdot (\text{TLS} - \text{TLR1})] / n$$

$$\text{Dumped heat recovery (QHD)} = K \cdot \Sigma [\text{FL} \cdot (\text{TLR1} - \text{TLR2})] / n$$

The loop fluid is expected to be water and not contain glycol, ( $K \sim 500 \text{ Btu/h-gpm-}^\circ\text{F}$ ). 'n' is the number of scan intervals included in each recording interval (e.g., with 1-minute data,  $n=60$ ).

#### Parasitic Loads

The parasitic electric loads on this system consists of a seven circulation pumps and two dump radiator fans.

The parasitic energy for the hot water booster pump will be calculated using a runtime measurement and a one-time power reading. The runtime of the pumps will be measured by current switch CTs wired in parallel, to capture the lead/lag operation of the two pumps.

$$\text{Parasitic Energy (WPAR)} = \text{WPAR}_{(\text{measured})} + \text{kW}_{\text{one-time P-5 + P-6}} / n$$

#### Calculated Quantities

The net power output from the CHP system will be defined as the power from the engine generators minus the parasitic power.

The fuel conversion efficiency of the CHP system, based on the lower heating value of the fuel, will be defined as:

$$FCE = \frac{QHU \cdot \Delta t + 3.412 \cdot (WG - WPAR)}{LHV_{gas} \cdot FG}$$

where:

QHU	-	Useful heat recovery (Btu/h)
WG	-	Engine generator gross output (kWh) (WG1+WG2)
WPAR	-	Parasitic energy (kWh)
FG	-	Generator gas consumption (Std CF)
$\Delta t$	-	1/60 for 1-minute data
$LHV_{gas}$	-	Lower heating value for natural gas (~905 Btu per CF).

Where

0.9 is the conversion factor between HHV and LHV

The FCE can be calculated for any time interval. When converting to daily, monthly, or annual values, each value is summed and then the following formula is applied:

$$FCE = \frac{\sum^N QHU \cdot \Delta t + 3.412 \cdot \sum^N (WG - WPAR)}{LHV_{gas} \cdot \sum^N FG}$$

Where N is equal to the number of intervals in the period of interest.

### **Data Logging Equipment**

The data logging system will be based around the Obvius Aquisuite A8812 data logger. The logger has eight analog or digital inputs on the main board, and monitoring capabilities can be extended using expansion boards. The primary sensor connection configuration for the logger is a two-wire twisted pair network, that reduces the number of low voltage sensor wire runs. The logger has 32 MB of onboard RAM for data retention. The logger is equipped with both a 10/100 LAN port and an analog phone modem for remote data retrieval.





*Obvious AcquiSuite*

**Figure 13. Obvious AcquiSuite Data Logger**

Each night we poll the logger via a network connection, and collect the data recorded across the day. Data are automatically loaded into the database system here at CDH Energy, where a number of automated data verification routines will identify any suspect data. Verification routines will consist of range checks, where the data are compared to a preset range of value, and data exceeding these values will be flagged; and/or relational checks, where the data are compared to the operational state of the unit for validity, such as “Are the engines consuming gas while producing power?” Data that fails the verification routines will be checked manually by CDH personnel on a daily basis, and corrupt data will be removed from the database. We will endeavor to address data collection issues such as data logging hardware or sensor failures within 48-hours of the failure being identified.

All data collected will be converted to hourly data in a comma delimited CSV format consistent with the requirements for inclusion into the NYSERDA integrated data system website.

All sensors are scanned on the order of once per second, and these samples will be combined into 1-minute averages (for analog data) and totals (for digital data). The logger has sufficient memory to hold up to 30-days of data without overwriting the logger memory.

All data logging equipment is installed in a fiberglass NEMA Type 1 enclosure to be mounted inside the mechanical room, near the existing Aegis control panel, providing 110 VAC and internet connectivity.

### **Other Monitoring Requirements**

The data logger will require a connection to the Internet. A dedicated static IP address is desired, but not required. If a dynamic IP address is used, the logger will upload data every night to the CDH Energy servers, but we will not be able to access the logger for remote configuration purposes.

All low voltage signal wiring will not be installed in conduit. Cable runs will be neat and secured to existing conduit.

### **Sensor Selection**

Cut sheets for the data logging equipment and sensors are attached.

### **Sensor Verification**

First year sensor verification completed on August 25, 2011.

### **System Energy Flows**

System energy and thermal flows documented in data analysis section.

### **Data Collection Status**

All sensors installed. Data being transferred to the NYSERDA Integrated Data System website.

Network connection to the data logger has been disrupted as of November 11, 2011. Data are being collected manually once per month from the data logger until this is corrected.

## **APPENDIX A – Data Logger and Sensor Cut Sheets**



# A8812 AcquiSuite DR™ Data Acquisition Server



## Description

Obvius, the leader in cost effective data acquisition and wireless metering solutions introduces the all-new A8812-x AcquiSuite DR™ data acquisition server, providing high performance and low cost for:

- Demand response programs
- Benchmarking building operations performance
- Verification of energy savings and utility costs
- Cost allocation to departments or tenants
- Internet based supervisory control outputs

The system combines the flexibility of choosing LAN, modem or cellular communication paths with the lowest total installed cost for logging building data such as:

- Electrical, gas and water usage and costs
- Indoor and outdoor temperatures
- Pressure, humidity, CO2
- Industry standard pulse or analog inputs

AcquiSuite™ brings “plug and play” capability to the data acquisition market, dramatically reducing the time and training required to put a typical building on line. In most applications, the installation can be done by the building engineer or contractor in less than 2 hours. The system automatically detects and configures Modbus devices in just seconds reducing installation time and costs.

## Applications

- Demand response program control and reporting
- Cost allocation to tenants and third parties
- Measurement & verification of energy savings
- Data center branch circuit monitoring
- Monitoring performance of building systems (e.g., chillers, boilers, fans)

## Easy installation saves time and money

- Simple “plug and play” connectivity to standard Modbus meters minimizes installation time and costs
- “Flex” I/O inputs provide easy connections for analog, pulse and resistance sensors
- Integrated relay outputs allow supervisory control from any location for load shedding or local generation
- Integrated web server provides setup and configuration using any industry standard web browser (i.e., Netscape™ or Internet Explorer™)

## AcquiSuite Framework lets users add Modbus devices

- Allows users a simple means to add Modbus devices not supported by AcquiSuite plug and play drivers
- Driver templates can be stored and shared with multiple AcquiSuites
- Simple web-based interface makes the process easy

## Internet display of key building parameters

- Buildingmanageronline.com™ allows authorized users to see building performance data in an easy to use graphical format
- BMO site provides storage, display and downloads of historical data in a secure SQL database
- Users can be notified of alarm conditions in any or all monitored points
- Open protocols provide connectivity to any energy management or building automation software

## Flexible communications and wireless connectivity

- All data is stored at the site in nonvolatile memory, insuring protection of valuable information in the event of power loss
- Optional on-board ModHopper (R9120-x) for wireless RS 485 communications (consult factory)
- A8812-1 provides two communication options: Local Area Network (LAN) or phone line
- A8812-GSM replaces the standard phone modem with a GSM/GPRS modem for cellular data transfer

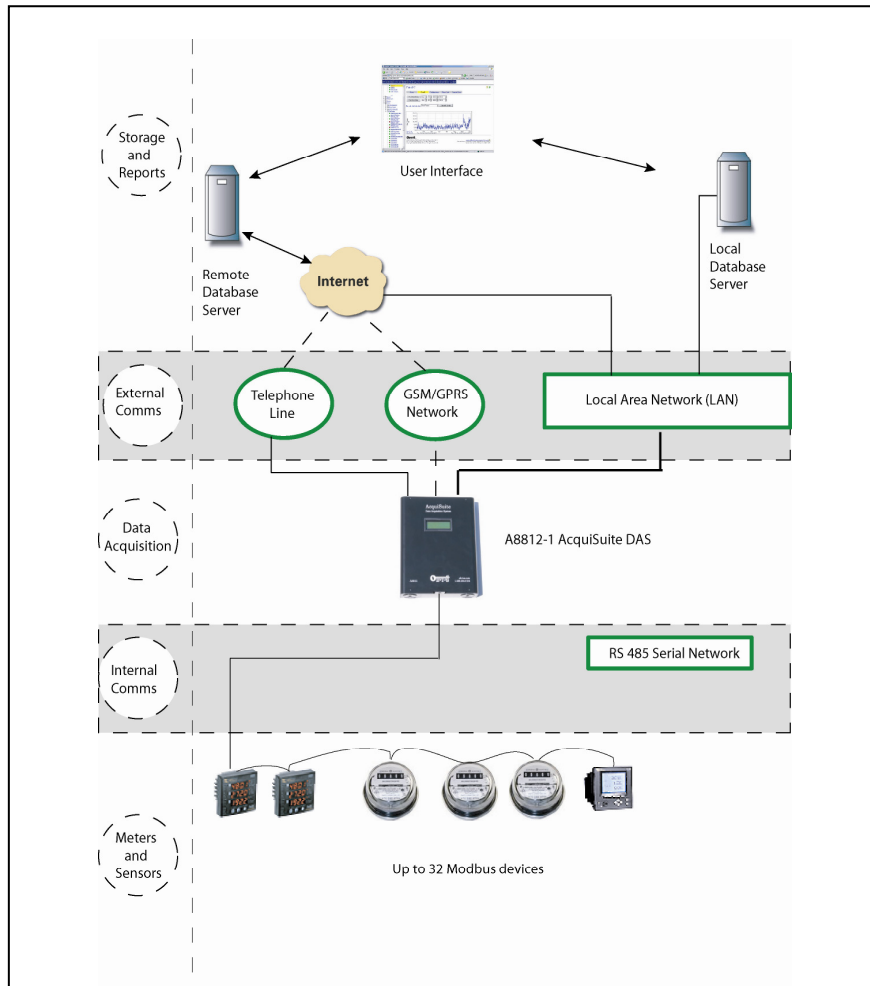

## SPECIFICATIONS

Processor	Main processor: ARM 9 ; I/O co-processor: ARM 7
Operating System	Linux 2.6
Flash ROM	16 MB NOR Flash (expandable with USB memory device)
Memory	32 MB RAM
LED	8x pulse input, 4 modem activity, Modbus TX/RX, power status
Console	2 x 16 LCD character, two buttons
LAN	10/100, Auto crossover detection
Modem (phone)	V.34 bis, 33,600 bps <b>(Part number A8812-1)</b>
Modem (cellular)	GSM/GPRS Class10, 85 kbps <b>(Part number A8812-GSM)</b>
Protocols	Modbus/RTU, Modbus/TCP, TCP/IP, PPP, HTTP/HTML, FTP,SNMP, SMTP, XML
Power Supply	24 VDC, included
Serial Port	RS-485 Modbus
Approvals	CE; FCC Part 15, Class A
USB port	USB memory expansion port
Power Requirement	110-120VAC
Interval recording	User selectable 1-60 minutes. Default 15 minute interval.
Outputs	2x, Dry contact 30 VDC, 150 mA max
Inputs	8x, user selectable: <ul style="list-style-type: none"> <li>• 0-10 V - Min/Max/Ave/Instantaneous</li> <li>• 4-20 mA - Min/Max/Ave/Instantaneous</li> <li>• Pulse- Consumption, Rate</li> <li>• Resistance - Min/Max/Ave/Instantaneous</li> <li>• Runtime - Runtime, Status</li> </ul>



**INTEGRAL SUBMETERING SOLUTION  
ELIMINATES THE NEED  
FOR SEPARATE ENCLOSURES**

**5 Year  
Warranty**

Patent #6,373,238



# Enercept® Self-Contained Split-Core kW/kWh Transducers

The Enercept H8040/H8050 Series kW (real power)/ kWh (consumption) transducers combine processing electronics and industrial grade CTs in an easy-to-install split-core package. These devices continuously measure voltage and current values for the monitored conductors and update calculations to provide highly accurate true RMS power readings. Models designed for balanced loads include one CT only, while models for unbalanced loads have three CTs.

The unique design of the H8040/H8050 Series transducers reduces the number of installed components, making them ideal for monitoring electrical power in commercial and industrial facilities. The H8040 uses industry-standard 4-20mA output, and the H8050 uses a pulse output.

Installation is simple. The H8040/H8050 eliminates the need to mount and wire a transducer and enclosure. CTs and voltage leads are color-matched, and the meters are designed to detect and automatically compensate for phase reversal. No more worries about CT load orientation.

**APPLICATIONS**

- Optimize chillers, pumps & cooling towers
- Energy managing & performance contracting
- Control processes
- Activity-based costing in commercial and industrial facilities
- Monitor real-time power

**Reduced installation and setup costs**

- Fast split-core installation eliminates the need to remove conductors...perfect for retrofits
- Precision meter electronics and current transformers in a single package – reduces the number of installed components – huge labor savings
- Smart electronics eliminate the need to be concerned with CT orientation...fast trouble-free installation

**High accuracy**

- ±1% total system accuracy, (10% to 100% of CT rating)

**SPECIFICATIONS**

<b>Input Primary Voltage</b>	208/240, or 480VAC RMS†
<b>Number of Phases Monitored</b>	One or Three
<b>Frequency</b>	50/60 Hz
<b>Maximum Primary Current</b>	Up to 2400 amps cont. per phase†
<b>Internal Isolation</b>	2000VAC RMS
<b>Insulation Class</b>	600VAC RMS††
<b>Temperature Range</b>	0° to 60°C, 50°C for 2400A
<b>Humidity Range</b>	0 - 95% non-condensing
<b>Accuracy</b>	1%
<b>Output</b>	(H8040) 4-20mA
<b>Supply Power (current loop)</b>	(H8040) 9-30VDC; 30mA max.
<b>Pulsed Output</b>	(H8050) Field -selectable; 1, 0.5, 0.25, 0.1kWh/pulse*
<b>Pulsed Output Type</b>	(H8050) Normally Open, Opto-FET, 100mA@24VDC
<b>Pulsed Width</b>	(H8050) 200 msec

† Contact factory to interface with voltages above 480 VAC or current above 2400 Amps.  
 †† Do not apply 600V Class current transformers to circuits having a phase-to-phase voltage greater than 600V, unless adequate additional insulation is applied between the primary conductor and the current transformers. Veris assumes no responsibility for damage of equipment or personal injury caused by products operated on circuits above their published ratings.  
 \* Count must be multiplied by the number of phases when using single CT models to monitor balanced multiphase systems.



**DIMENSIONAL DRAWINGS**

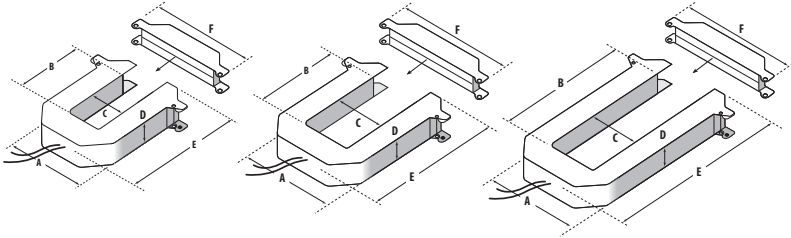

**SMALL**  
100/300 Amp

A = 3.8" (96 mm)  
B = 1.2" (30 mm)  
C = 1.3" (31 mm)  
D = 1.2" (30 mm)  
E = 4.0" (100 mm)  
F = 4.8" (121 mm)

**MEDIUM**  
400/800 Amp

A = 4.9" (125 mm)  
B = 2.9" (73 mm)  
C = 2.5" (62 mm)  
D = 1.2" (30 mm)  
E = 5.2" (132 mm)  
F = 5.9" (151 mm)

**LARGE**  
800/1600/2400 Amp

A = 4.9" (125 mm)  
B = 5.5" (139 mm)  
C = 2.5" (62 mm)  
D = 1.2" (30 mm)  
E = 7.9" (201 mm)  
F = 6.0" (151 mm)

**APPLICATION/WIRING EXAMPLES**

*H8040/H8050 208 or 480VAC 3Ø, 3/4 Wire*

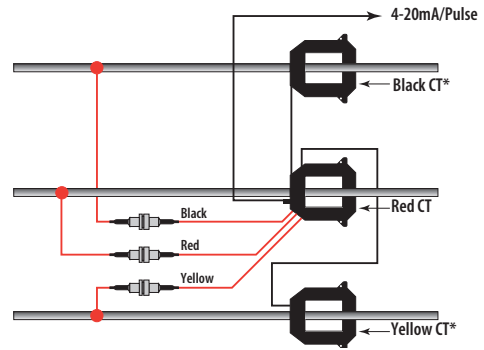

*H8040 240VAC 1Ø, 3-Wire*

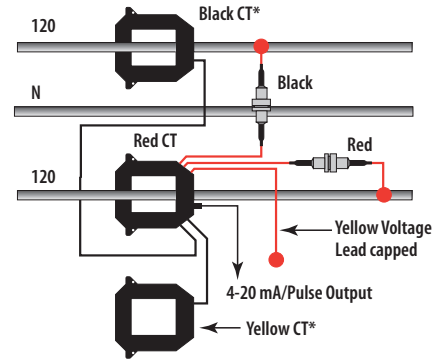

*H8050 277VAC 1Ø, 2-Wire*

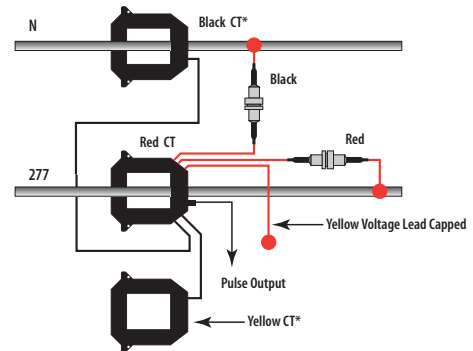

**ORDERING INFORMATION**

Single CT Models for Use with Balanced 3Ø Loads  
Three CT Models for Use with Unbalanced 3Ø Loads



MODEL	VOLTAGE	MAX. AMPS	OUTPUT	CT SIZE	CT TYPE
H8041-0100-2	208/240	100	4-20mA	SMALL	Single CT Model
H8041-0300-2		300		SMALL	
H8041-0400-3		400		MEDIUM	
H8041-0800-3		800		MEDIUM	
H8041-0800-4		800		LARGE	
H8041-1600-4		1600		LARGE	
H8041-2400-4	2400	LARGE	LARGE		
H8042-0100-2	480	100	4-20mA	SMALL	Single CT Model
H8042-0300-2		300		SMALL	
H8042-0400-3		400		MEDIUM	
H8042-0800-3		800		MEDIUM	
H8042-0800-4		800		LARGE	
H8042-1600-4		1600		LARGE	
H8042-2400-4	2400	LARGE	LARGE		
H8043-0100-2	208/240	100	4-20mA	SMALL	Three CT Model
H8043-0300-2		300		SMALL	
H8043-0400-3		400		MEDIUM	
H8043-0800-3		800		MEDIUM	
H8043-0800-4		800		LARGE	
H8043-1600-4		1600		LARGE	
H8043-2400-4	2400	LARGE	LARGE		
H8044-0100-2	480	100	4-20mA	SMALL	Three CT Model
H8044-0300-2		300		SMALL	
H8044-0400-3		400		MEDIUM	
H8044-0800-3		800		MEDIUM	
H8044-0800-4		800		LARGE	
H8044-1600-4		1600		LARGE	
H8044-2400-4	2400	LARGE	LARGE		

MODEL	VOLTAGE	MAX. AMPS	OUTPUT	CT SIZE	CT TYPE
H8051-0100-2	208/480	100	Pulse	SMALL	Single CT Model
H8051-0300-2		300		SMALL	
H8051-0400-3		400		MEDIUM	
H8051-0800-3		800		MEDIUM	
H8051-0800-4		800		LARGE	
H8051-1600-4		1600		LARGE	
H8051-2400-4	2400	LARGE	LARGE		
H8053-0100-2	208/480	100	Pulse	SMALL	Three CT Model
H8053-0300-2		300		SMALL	
H8053-0400-3		400		MEDIUM	
H8053-0800-3		800		MEDIUM	
H8053-0800-4		800		LARGE	
H8053-1600-4		1600		LARGE	
H8053-2400-4	2400	LARGE	LARGE		

**HIGH ACCURACY  
SPECIALTY SENSORS**



TA



Averages the temperature across the duct

TB



Pipe clamps secure sensor to the pipe, a copper sensing plate is used for fast response

TRA



Stainless steel remote probe, designed for high accuracy

# Specialty Temperature Sensors

The TA Series averages the temperature read across the entire length of its copper tubing, making it an ideal product for duct temperature measurements.

The TB strap-on sensor uses a clamp to secure the unit to a pipe, and a copper sensing plate for fast temperature response. The TB is perfect for secondary measurement of water temperature typical in retrofit applications. All TB Series temperature sensors include a steel mounting box for wire termination and easy conduit connection.

The TRA Series stainless steel remote probe is designed for high accuracy in remote temperature sensing applications. These units can be used in numerous refrigeration applications, or they can be mounted on pipes for chilled or heated water temperature sensing. All TRA Series temperature sensors are easily installed and include a durable stainless steel sensing probe and a two-wire twisted pair wire with strain relief.

**TA Averaging Sensor**

- Temperature averaging sensors average the temperature across the duct in 6', 12', or 24' (1.8m, 3.6m, or 7.3m) lengths
- Copper tubing enhances response time

**TB Pipe Surface Sensor**

- Secondary measurement of water temperature... ideal for retrofit applications
- Pipe clamps allow for easy installation on pipes up to 12" in diameter

**TRA Probe Sensor**

- Durable stainless steel sensing probe

**SPECIFICATIONS**

<b>Wiring</b>	22AWG; 2-wire:RTD/Thermistor
<b>Linitemp:</b>	
<b>Input Power</b>	5 to 30VDC
<b>Output</b>	1µA/°C or 10mV/°C
<b>Operating Temperature</b>	-25° to 105°C (-13° to 221°F)
<b>Accuracy</b>	Calibration Error: 1.5°C (35°F) typical; 2.5°C (37°F) max. at 25°C (77°F)*
	Error over Temperature: 1.8°C typical (35°F); 3.0°C (34°F) max. over 0° to 70°C (32° to 158°F) range
	2.0°C (35°F) typical, 3.5°C (38°F) max. over -25° to 105°C (-13° to 221°F) range

\*Room temperature error documented on each unit.



**DIMENSIONAL DRAWINGS**

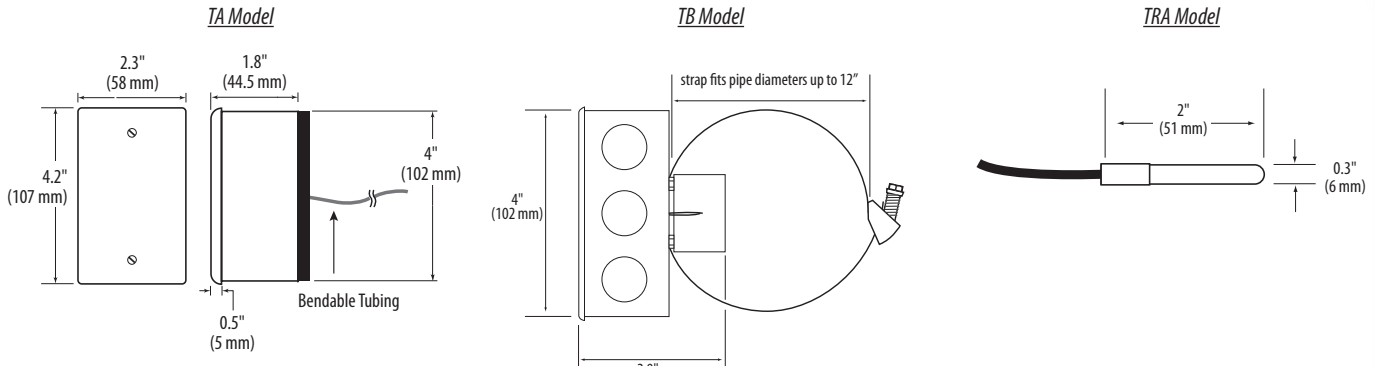

Class	Pt RTD		THERMISTOR									
Type	100 Ohm	1000 Ohm	2.2k	3k	10k Type 2	10k Type 3	10k Dale	10k 3A221	10k "G" US	20k	20k "D"	100k
Accuracy	±0.3°C	±0.3°C	±0.2°C	±0.2°C	±1.0°C	±0.2°C	±0.2°C	±1.1°C	±0.2°C	Consult	Consult	Consult
Temp. Response*	0.0385 curve	0.0385 curve	0/70°C	0/70°C	-50/150°C	0/50°C	-20/70°C	0/70°C	0/70°C	Factory	Factory	Factory
	PTC	PTC	NTC	NTC	NTC	NTC	NTC	NTC	NTC	NTC	NTC	NTC

\*PTC: Positive Temperature Coefficient  
 \*NTC: Negative Temperature Coefficient

**To compute Linitemp Temperature:**

- 2-Wire version (1µA/°C)  
µA reading - 273.15 = Temperature in °C
- 3-Wire version (10mV/°C)  
mV reading/10 - 273.15 = Temperature in °C

**STANDARD RTD AND THERMISTOR VALUES (Ohms Ω)**

°C	°F	100 Ohm	1000 Ohm	2.2k	3k	10k Type 2	10k Type 3	10k Dale	10k 3A221	10k "G" US	20k	20k "D"	100k
-50	-58	80.306	803.06	154,464	205,800	692,700	454,910	672,300	-	441,200	1,267,600	-	-
-40	-40	84.271	842.71	77,081	102,690	344,700	245,089	337,200	333,562	239,700	643,800	803,200	3,366,000
-30	-22	88.222	882.22	40,330	53,730	180,100	137,307	177,200	176,081	135,300	342,000	412,800	1,770,000
-20	-4	92.160	921.60	22,032	29,346	98,320	79,729	97,130	96,807	78,910	189,080	220,600	971,200
-10	14	96.086	960.86	12,519	16,674	55,790	47,843	55,340	55,252	47,540	108,380	122,400	553,400
0	32	100.000	1000.00	7,373	9,822	32,770	29,588	32,660	32,639	29,490	64,160	70,200	326,600
10	50	103.903	1039.03	4,487	5,976	19,930	18,813	19,900	19,901	18,780	39,440	41,600	199,000
20	68	107.794	1077.94	2,814	3,750	12,500	12,272	12,490	12,493	12,260	24,920	25,340	124,900
25	77	109.735	1097.35	2,252	3,000	10,000	10,000	10,000	10,000	10,000	20,000	20,000	100,000
30	86	111.673	1116.73	1,814	2,417	8,055	8,195	8,056	8,055	8,194	16,144	15,884	80,580
40	104	115.541	1155.41	1,199	1,598	5,323	5,593	5,326	5,324	5,592	10,696	10,210	53,260
50	122	119.397	1193.97	811.5	1,081	3,599	3,894	3,602	3,600	3,893	7,234	6,718	36,020
60	140	123.242	1232.42	561.0	747	2,486	2,763	2,489	2,486	2,760	4,992	4,518	24,880
70	158	127.075	1270.75	395.5	527	1,753	1,994	1,753	1,751	1,990	3,512	3,100	17,510
80	176	130.897	1308.97	284.0	378	1,258	1,462	1,258	1,255	1,458	2,516	2,168	12,560
90	194	134.707	1347.07	207.4	-	919	1,088	917	915	1,084	1,833	1,542	9,164
100	212	138.506	1385.06	153.8	-	682	821	679	678	816.8	1,356	1,134	6,792
110	230	142.293	1422.93	115.8	-	513	628	511	509	623.6	1,016	816	5,108
120	248	146.068	1460.68	88.3	-	392	486	389	388	481.8	770	606	3,894
130	266	149.832	1498.32	68.3	-	303	380	301	299	376.4	591	456	3,006

**ORDERING INFORMATION**

**Strap-on Brackets**

**TB**  A = 2 1/2" max. diameter  
 D = 8" max. diameter  
 E = 12" max. diameter

**TRA** *Remote Probe*

**Sensor Type**

B = 100R platinum, RTD  
 C = 1k platinum, RTD  
 D = 10k T2, Thermistor  
 E = 2.2k, Thermistor  
 F = 3k, Thermistor  
 G = 10k CPC, Thermistor  
 H = 10k T3, Thermistor  
 J = 10k Dale, Thermistor  
 K = 10k w/11k shunt, Thermistor  
 M = 20k NTC, Thermistor  
 N = 1800 ohm, Thermistor  
 P = 10mV/°C, Linitemp  
 R = 10k US, Thermistor  
 S = 10k 3A 221, Thermistor  
 T = 100k, Thermistor  
 U = 20k "D", Thermistor

**Cal Certificate**

0 = None  
 1 = 1 point Cal validation  
 2 = 2 point Cal validation

**Examples:**

TB  D  C  2  
 TRA  F  1

**Probe Length**

**TA**  \*M = 6' (1.8m)  
 H = 12' (3.6m)  
 J = 24' (7.3m)

**Sensor Type**

B = 100R platinum, RTD  
 C = 1k platinum, RTD  
 D = 10k, T2, Thermistor  
 H = 10k, T3, Thermistor  
 J = 10k, Dale, Thermistor  
 M = 20k, NTC  
 N = 1800 ohm, Thermistor  
 P = 10mV/°C, Linitemp  
 R = 10k US, Thermistor

**Cal Certificate**

0 = None  
 1 = 1 point Cal validation  
 2 = 2 point Cal validation

**Example:**

TA  H  C  2

\*Available with sensor types J,N,P

NOTE: For 4-20mA transmitter output, order sensor with the 100Ω platinum RTD and accessory AA10xx. See page 209.



THE WATTNODE is a true RMS AC watt-hour transducer with pulse output (solid state relay closure) proportional to kWh consumed. The WATTNODE provides accurate measurement at low cost to meet your needs for sub-metering, energy management and performance contract applications.

**Easy Installation** saves you time and money. The WATTNODE is small enough to fit entirely within a standard electrical panel and the screw terminals unplug for easy wiring.

The **Advanced Output** includes separate pulse channels for positive and negative power, for net metering and PV metering. Optional models are available with one pulse output channel per measurement phase, which can be used to monitor each phase independently or to monitor three separate single-phase circuits with one WattNode.

Our **Diagnostic LEDs** provide a per-phase indication of power (green flashing), negative power (red flashing), and advanced diagnostics (yellow flashing) to help troubleshoot connection problems, like swapped CTs, or excessive line voltage. See the User's Guide for a full description.

The **Pulse Series** family measures 1, 2, or 3 phases in 2, 3 or 4 wire configurations. With voltage ratings from 120 to 600 VAC and current transformer (CT) rating from 5 to 4000 amps, there is a WATTNODE combination to meet your AC power measurement requirements.

**ACCURACY** of the WATTNODE is 0.5% of reading over a wide range of power factors and harmonic content. You get true kWh measurements even with switching power supplies and variable speed drives.

Our **Safe CTs**, with internal burden resistors produce a voltage proportional to the load current. At rated current voltage is only 0.333 VAC. Split-core CTs quickly install on existing wiring and solid-core CTs cost less for new wiring.

277/480  
VAC  
120/240

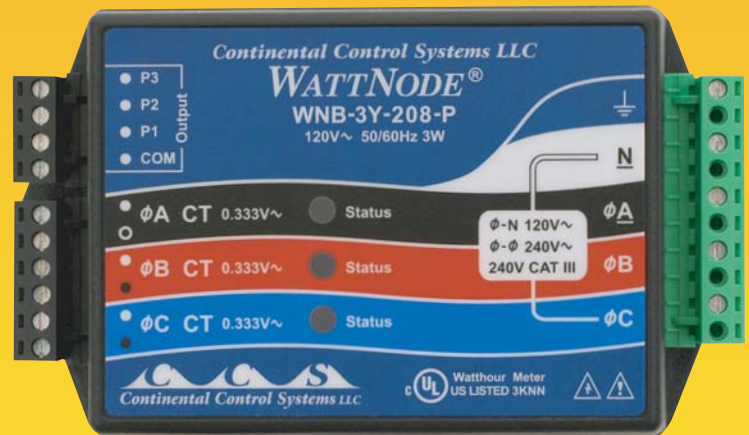

(888) 928-8663



Continental Control Systems LLC  
3131 Indian Road, Suite A  
Boulder, CO 80301 USA  
(888) 928-8663 Fax (303) 444-2903  
sales@ccontrols.com

www.ccontrols.com

• **Advanced Pulse Output**

Separate pulse channels for positive and negative power. Optional models are available with one pulse output channel per measurement phase.

• **Small Size**

Can be installed in existing service panels or junction boxes.

• **Uses Safe CTs**

Output limited to one volt.

• **Line Powered**

No external power supply required.

• **Digital Signal Processing**

Accurate kWh measurement over a wide harmonic range.

• **Detachable Terminal Blocks**

Easy to install and remove.

# SPECIFICATIONS

## Measurement Configurations

- Single phase: 2-wire or 3-wire
- Three phase: 3-wire or 4-wire

## Electrical

- Line Powered
- Operating Voltage Range: +15%, -20% of nominal
- Power Line Frequency: 50/60 Hz
- CT Input: 0.333 VAC

## Pulse Output

- Optoisolated, solid state relay closures handle up to maximum 60 VDC & to 5mA
- Standard: 4.00 Hz Bidirectional Output
- Optional: 0.01 Hz to 600 Hz Bidirectional Output Models
- Optional: Per-Phase Output Models 0.01 Hz to 150 Hz available

## Accuracy

- Normal Operation: Line voltage: 80% - 115% of nominal
- Power factor: 1.0
- Frequency: 50- 60 Hz
- Ambient Temperature: 25°C
- Current: 5% - 100% of rated current
- Accuracy: ±0.5% of reading

## Environmental

- Operating Temperature: -30°C to +55°C (-22°F to 131°F)
- Operating Humidity: 5 to 90% (RH)

## Mechanical

- Enclosure: High impact, UL rated, ABS plastic
- Size: 3.3" x 5.6" x 1.5"
- Connectors: UL, CSA recognized, detachable, screw terminals (14AWG), 600V

## Optional LCD Display

- Display: Eight digits, each 0.43" high
- Reset: Wired remote and configurable front panel button
- Enclosure: Panel mount box, 2.95" x 1.52"
- Battery: Lithium 2/3A, replace every four years

# WATTNODE®

## Advanced Pulse Output AC Power Measurement

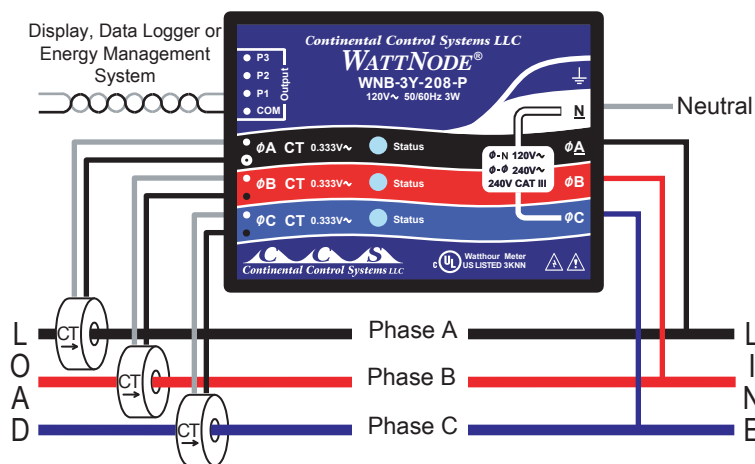

## WATTNODE

Model	VAC		Phases	Wires
	Line To Neutral	Line To Line		
WNB-3Y-208-P	120	208-240	3	4
WNB-3Y-400-P	230	400	3	4
WNB-3Y-480-P	277	480	3	4
WNB-3Y-600-P	347	600	3	4
WNB-3D-240-P	120	208-240	3	3
WNB-3D-400-P	230	400	3	3
WNB-3D-480-P	277	480	3	3

## LCD Displays

Model	Displays	Units
LCDA-E	Energy	WH, kWh, or MWh
LCDA-P	Power	W or kW
LCDA-EP	Energy & Power	WH, kWh, or MWh & W or kW

## OPENING CURRENT TRANSFORMERS (SPLIT-CORE)

Model	Inside Diameter	Rated Amps
CTS-0750	0.75"	5, 15, 30, 50, 70, 100, 150
CTS-1250	1.25"	70, 100, 150, 200, 250, 300, 400, 600
CTS-2000	2.00"	600, 800, 1000, 1200, 1500
CTB	Bus Bar	600, 800, 1200, 2000, 3000 (custom)

## TOROIDAL CURRENT TRANSFORMERS (SOLID-CORE)

Model	Inside Diameter	Rated Amps
CTT-0300	0.30"	5, 15, 30
CTT-0500	0.50"	15, 30, 50, 60
CTT-0750	0.75"	30, 50, 70, 100
CTT-1000	1.00"	50, 70, 100, 150, 200
CTT-1250	1.25"	70, 100, 150, 200, 250, 300, 400

MADE IN THE USA

(888) 928-8663



3131 Indian Road, Suite A  
Boulder, CO 80301

(888) 928-8663 Fax (303) 444-2903  
sales@ccontrols.com

www.ccontrols.com

Current Transformer Output Voltage: 0 - 0.333 VAC @ rated current



# **FLOWMETER**

## **ENGINEERING MANUAL**

### **1800 SERIES**



**FLOW MEASUREMENT & CONTROL SOLUTIONS**

## **PRODUCT OVERVIEW**

ISTEC's "Super-Jet" 1800 Series are industrial grade water meters available in ½" through 12" sizes. All sizes incorporate a variety of standard features such as U.S. gallon register, hermetically sealed non-resettable counter, trickle flow indicator and pulse output. ISTEC "Super-Jet" design leaves only the turbine immersed, resulting in reliable and long lasting performance.

For easy installation, all ISTEC flow meters up to 1½" are available with union connections; 2" and larger sizes are designed with standard flanges. The smooth running turbine, together with a self-aligning suspension bearing system and other innovative features provides superior reliability and accuracy that meets or exceeds AWWA standards.

In addition, a high temperature version (350°F) of the 2", 3" and 4" meters is available.

## **COMPONENT DESCRIPTION**

### **BODY**

Pipe Size ½" (15mm) To 1½" (40mm)	Brass
Pipes Size 2" (50mm) To 12" (300mm)	Cast Iron

### **FLOW INSERT**

Turbine	Fiberglass
Turbine Axle	Chrome/Nickel/Steel
Bearing Material	Stainless Steel/Sapphire
Magnetic Transfer	Cobalt/Samarium
Gears, Axles, Screws	Stainless Steel

### **COUNTER**

Calibration	U.S. Gallons (Metric Available)
Housing	Plastic, Hermetically Sealed
Gears	Plastic
Axles	Chrome/Nickel/Steel

### **ENVIRONMENTAL**

Maximum Temperature	248°F (120°C)
Maximum Pressure	232 PSI (16 BAR)

## TECHNICAL SPECIFICATIONS

P/N		1800	1805	1810	1811/12	1815	1816	1820	
F L O W	R A N G E	MIN	0.13 gpm	0.22 gpm	0.4 gpm	0.4 gpm	0.7 gpm	0.7 gpm	0.88 gpm
			30 lph	50 lph	90 lph	90 lph	160 lph	160 lph	200 lph
		CONT	6.6 gpm	11 gpm	26.32 gpm	26.32 gpm	43.86 gpm	43.86 gpm	65.8 gpm
			1.5 m <sup>3</sup> ph	2.5 m <sup>3</sup> ph	6 m <sup>3</sup> ph	6 m <sup>3</sup> ph	10 m <sup>3</sup> ph	10 m <sup>3</sup> ph	15 m <sup>3</sup> ph
		MAX	13.2 gpm	22 gpm	52.6 gpm	52.6 gpm	87.22 gpm	87.22 gpm	131.6 gpm
3 m <sup>3</sup> ph	5 m <sup>3</sup> ph		12 m <sup>3</sup> ph	12 m <sup>3</sup> ph	20 m <sup>3</sup> ph	20 m <sup>3</sup> ph	30 m <sup>3</sup> ph		
PULSE	gal/pulse	1	1	1	1	1	1	10	
	liters/pulse	1	1	1	1	1	1	10	
WEIGHT	pounds	2.3	2.5	6.4	6.8	11.3	12.1	27.5	
	kilograms	1	1.1	2.9	3.1	5.1	5.5	12.5	
P/N		1825	1830	1835	1840	1845	1850	1855	
F L O W	R A N G E	MIN	2.64 gpm	14.09 gpm	5.26 gpm	26.32 gpm	43.86 gpm	53 gpm	66 gpm
			0.6 m <sup>3</sup> ph	3.2 m <sup>3</sup> ph	1.2 m <sup>3</sup> ph	6 m <sup>3</sup> ph	10 m <sup>3</sup> ph	12 m <sup>3</sup> ph	15 m <sup>3</sup> ph
		CONT	66.04 gpm	140.89 gpm	263.2 gpm	657.9 gpm	1096.5 gpm	1761 gpm	2642 gpm
			15 m <sup>3</sup> ph	32 m <sup>3</sup> ph	60 m <sup>3</sup> ph	150 m <sup>3</sup> ph	250 m <sup>3</sup> ph	400 m <sup>3</sup> ph	600 m <sup>3</sup> ph
		MAX	264.2 gpm	396.26 gpm	790 gpm	1535 gpm	2631 gpm	4400 gpm	5284 gpm
60 m <sup>3</sup> ph	90 m <sup>3</sup> ph		180 m <sup>3</sup> ph	350 m <sup>3</sup> ph	600 m <sup>3</sup> ph	1000 m <sup>3</sup> ph	1200 m <sup>3</sup> ph		
PULSE	gal/pulse	10	10	10	100	100	100	100	
	liters/pulse	10	10	10	100	100	100	100	
WEIGHT	pounds	24.4	27.5	43.7	71.6	99.2	260.0	300.0	
	kilograms	11.1	12.5	19.8	32.5	45	118	136	

## TYPICAL FLOWMETER ACCURACY CHART

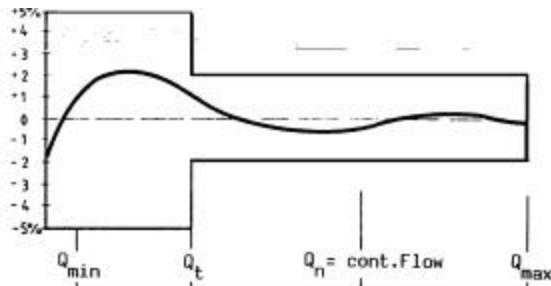

## DIMENSIONS

P/N	<b>1800</b>	<b>1805</b>	<b>1810</b>	<b>1811/12</b>	<b>181</b>	<b>1816</b>	<b>1820</b>
Size	½"(H) 15mm	¾" (A) 20mm	1" (H) 25mm	1" (D) 25mm	1½" (H) 40mm	1½" (D) 40mm	2"(H) 50mm
h	¾" 20mm	¾" 20mm	1-¾" 45mm	1-¼" 31mm	2" 50mm	7/8" 21mm	3-¼" 83mm
H	3-¾" 95mm	3-¾" 95mm	5-½" 140mm	7-½" 191mm	6-¼" 155mm	8-¾" 221mm	7-⅛" 180mm
L	4-½" 114mm	5" 127mm	10-¼" 260mm	5-7/8" 150mm	11-7/8" 300mm	7-7/8" 200mm	10-½" 270mm
P/N	<b>1825</b>	<b>1830</b>	<b>1835</b>	<b>1840</b>	<b>1845</b>	<b>1850</b>	<b>1855</b>
Size	2"(A) 50mm	3"(A) 80mm	4"(A) 100mm	6"(A) 150mm	8"(A) 200mm	10"(A) 250mm	12"(A) 300mm
h	3" 75mm	3-¾" 94mm	4-3/8" 110mm	5-3/4" 145mm	6-3/4" 172mm	8" 203mm	9-½" 241mm
H	5-½" 141mm	5-½" 141mm	7-7/8" 200mm	8-½" 217mm	8-½" 217mm	9-¼" 240mm	10-¼" 260mm
L	7-7/8" 200mm	8-7/8" 225mm	9-7/8" 250mm	11-7/8" 300mm	13-3/4" 350mm	17-3/4" 450mm	19-3/4" 502mm

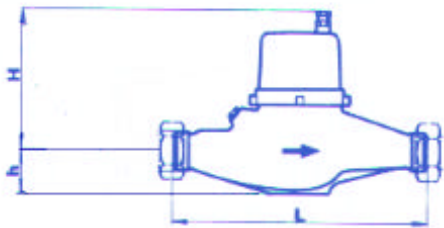

**Flowmeter ½" to 1-1/2"**

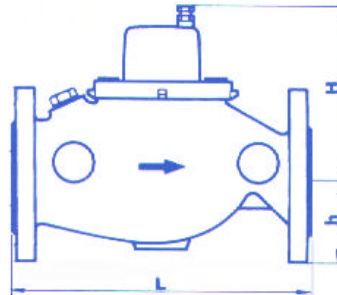

**Flowmeter 2" to 12"**

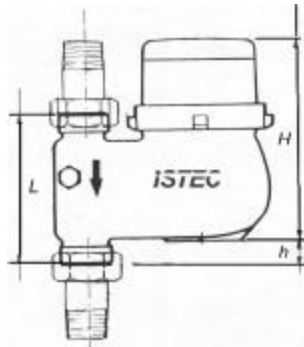

**Flowmeter 1" & 1-1/2" Downflow / Upflow**

# **FLOWMETER SPECIFICATION: 1800 SERIES**

## **AS MANUFACTURED BY ISTECH CORPORATION**

**5 Park Lake Road, Sparta, NJ 07871**

The contractor shall furnish and install as shown on the plans a multi-wing turbine type Flowmeter. The Flowmeter shall be factory assembled, calibrated and tested, incorporating the following features:

### **BODY**

The Flowmeter shall have a line size of \_\_\_\_\_ inch(s)/\_\_\_\_\_mm(s). The body shall be constructed of brass (from ½” (15mm) to 1-1/2” (40mm) sizes) or cast iron (from 2” (50mm) to 12” (300mm)).

### **FLOW INSERT**

The Flow Insert shall be the “single-jet” type on the ½” (15mm) and ¾” (20mm) sizes. It shall be the “multi-jet” style on the 1” (25mm) through 12” (300mm) sizes. The insert assembly shall be capable of being replaced without removing the meter body.

### **COUNTER**

The unit shall have a hermetically sealed “dry-type” mechanical counter. The counter will read in U.S. gallons (cubic meters available) and shall be non-resettable.

### **ACCURACY**

The Flowmeter shall have an accuracy of  $\pm 1.5\%$ .

### **FLOW RANGE**

The Flowmeter shall have a minimum flow rating of \_\_\_\_\_ gpm (\_\_\_\_\_ lph/or m<sup>3</sup>ph). It shall have a continuous flow rating of \_\_\_\_\_ gpm (\_\_\_\_\_ m<sup>3</sup>ph). The peak flow, which the meter can not be subjected to for more than one hour per day, shall be \_\_\_\_\_ gpm (\_\_\_\_\_ m<sup>3</sup>ph).

### **PULSER**

The Flowmeter shall provide a “pulse” type output of 1 contact closure for every 1/10/100 gallon(s) of flow (metric counters provide 1 pulse for every 1/10/100 liters of flow).



## **APPENDIX B – Data Logger Wiring Diagrams**

# Instrumentation, Wiring Schematic, and Installation Details

## Site Visits

June 10, 2010	Initial Visit (Adam Walburger)
July 27, 2010	Datalogger and sensors installation. DAS system operational but incomplete, partially verified sensor readings (Adam Walburger, Jeff Cosgrove).
August 1, 2010	Gas data are collected from monthly Con Ed meter readings (via internet). Monitoring period begins.
August 25, 2011	Environmental testing performed. First year CHP verification performed.
September 22, 2011	Internet connection from logger severed at site. Clock drift begins from lack of internet connection
November 11, 2011	CDH performs manual data collection from logger
December 19, 2011	CDH performs manual data collection from logger Engine tuning and Environmental testing performed.

## Description of Monitored Data Points and Schematics

Table B-1 lists the monitored points installed at the site. The wiring Schematics are shown in and .

**Table B-1. Monitored Data Point List**

No	Data Point	Description	Sensors	Units	Notes
1	WG1	Engine generator #1 energy	Veris H8053-400	kWh	No meter supplied by applicant - CDH Energy will supply power meter 0.1 kWh/pulse
2	WG2	Engine generator #2 energy	Veris H8053-400	kWh	No meter supplied by applicant - CDH Energy will supply power meter 0.1 kWh/pulse
3	WPAR	Parasitic energy (pumps, dump radiator fans)	Wattnode WNB-3Y-208-P	kWh	No meter supplied by applicant - CDH Energy will supply power meter 1.25 Wh/pulse, 50-AMP CTs
4	TLS	Heat recovery loop supply temperature	Type II 10k Ohm Thermistor	deg F	CDH Energy to supply strap-on style sensor
5	TLR1	Heat recovery loop return temperature after load HXs	Type II 10k Ohm Thermistor	deg F	CDH Energy to supply strap-on style sensor
6	TLR2	Heat recovery loop return temperature after dump radiator	Type II 10k Ohm Thermistor	deg F	CDH Energy to supply strap-on style sensor
7	FL	Heat recovery loop flow	ISTEC 1820 flow meter	gallons	Applicant supplied meter, 10 gallon/pulse
8	FG	Natural gas	Con Ed Billing Meter (monthly reads)	CCF	No access to natural gas meter is available, revenue meter is located in basement meter room with no connecting conduit. Con-Ed monthly billing data used to for natural gas consumption.

**Obvius Acquisite A8812 -1 Data Logger  
Input Terminals**

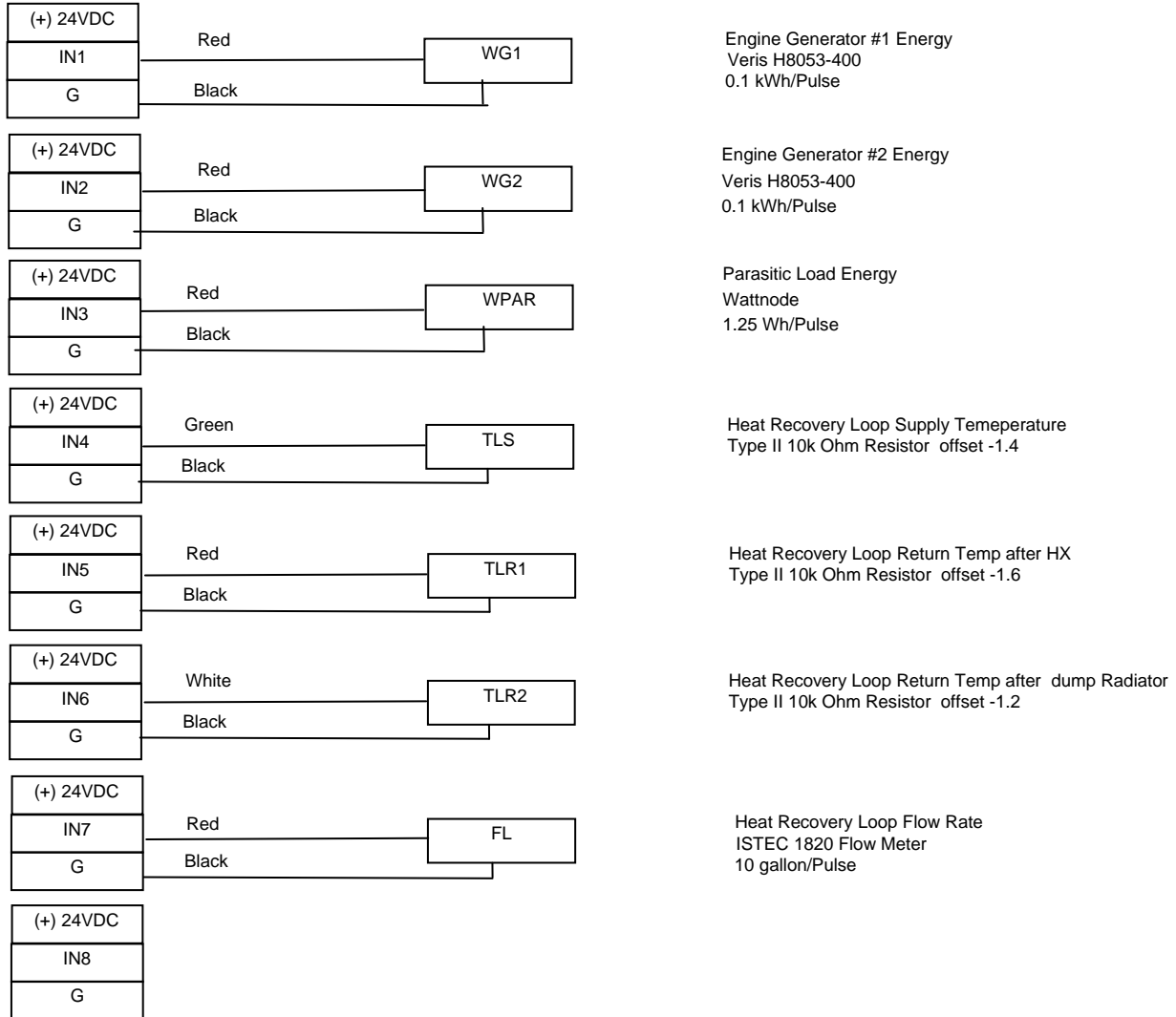

**Figure B-1. Obvius Data Logger Wiring Schematic**

## Photos of Installed Sensors

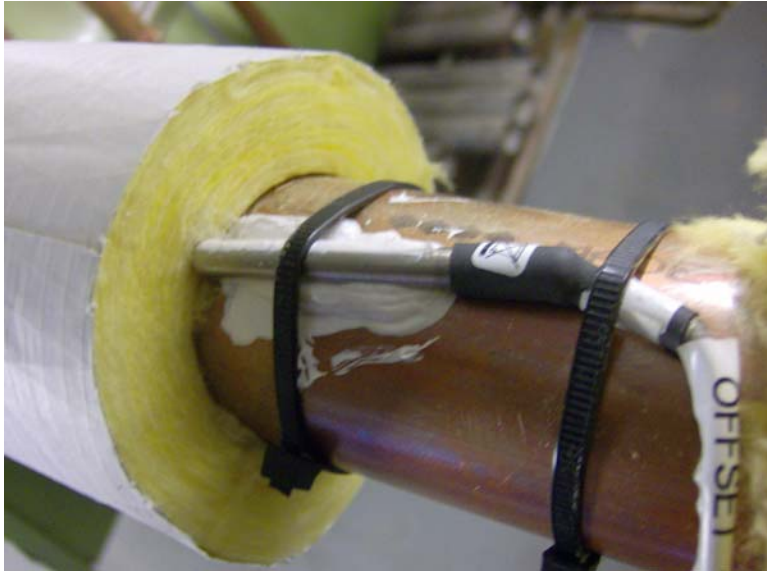

Figure B-2. Thermistor Installation (typ.)

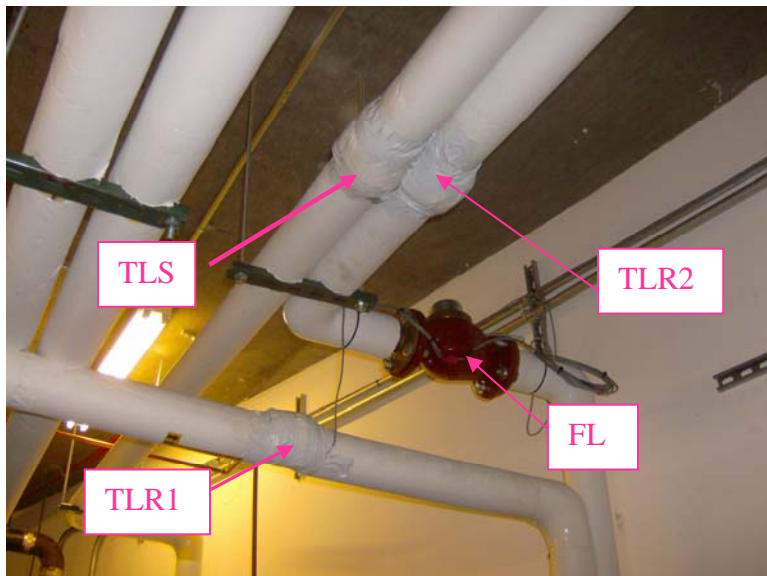

Figure B-3. Thermistor and Flowmeter Locations



**Figure B-4. Parasitic Power Watt-Node Power Transducer In 208 VAC panel**

Engine power meters located in each engine control compartment (no photo available).



## First Year CHP Verification – August 25, 2011

Verification of the DAS system monitoring was performed on August 25, 2011. Readings from three system power meters, three temperature sensors, and heat recovery loop flow meter were all compared to independent readings from handheld sensors or other site-located sensors (thermometers, engine displays, etc).

No DAS sensor was found to be outside of reasonable agreement with the independent measurements.

**Table 2. Power Transducer Readings**

<b>Sensor</b>	<b>DAS Reading (kW)</b>	<b>Extech 380940 Watt Probe Reading (kW)</b>	<b>AGEN 75 Display Panel Reading (kW, RPM)</b>
WG1 – CHP Unit #1 Gross Output	60.0 kW	60.5 kW	60.0 kW @ 1,818 RPM
WG2 – CHP Unit #2 Gross Output	62.0 kW	62.0 kW	60.0 kW @ 1,818 RPM
WPAR – CHP Parasitic Power Panel	2.5 kW	2.5 kW	n/a

**Table 3. Heat Recovery Loop Temperatures**

<b>Sensor</b>	<b>DAS Reading (°F)</b>	<b>Fluke 51II Thermometer Handheld Probe Reading (°F)</b>	<b>Dial Thermometer Reading (°F)</b>
TLS - Heat recovery loop supply temperature	193.6	193.8	188
TLR1 – Heat recovery loop temperature after HX (Useful heat)	144.9	145.8	148
TLR1 – Heat recovery loop temperature after Dump HX (Dumped heat)	141.1	138.9	140

**Table 4. Heat Recovery Loop Flow Rate**

<b>Sensor</b>	<b>DAS Reading (gpm)</b>	<b>Fuji Ultrasonic Flow Meter Reading (L/s, gpm)</b>
FL - Heat recovery loop flow rate	30 gpm	1.9-2.0 L/s = 31 gpm

**Table 5. 208 VAC Parasitic Load Panel Component Readings**

<b>Parasitic Equipment</b>	<b>Measured Power (Extech 380940 Watt Probe) (W, kW)</b>	<b>Notes</b>
Pump P1 – Cogen Pump	810 W	Operates with engine
Pump P2 – Cogen Pump	790 W	Operates with engine
Pump 3A – HR Loop Pump	520 W	Operates continuously
Pump 3B – HR Loop Pump	270 W	Operates continuously
Pump 5 – DHW Pump	400 W	Operates continuously
Pump 6 – DHW Pump	400 W	Operates continuously
<b>Total</b>	<b>2,390 W (2.4 kW)</b>	